



Alabama State Port Authority
Requisition and Proposal

Project Name Blakeley Fender Repair

Project No. 11127 Task No. 01

To: Prospective Bidders

Date: September 2022

Please procure the following and deliver to the address below:

<p><u>Delivery of Proposal:</u> Alabama State Port Authority (ASPA) Location identified below in Note #1</p>	<p><u>Delivery of Performance of Work:</u> Alabama State Port Authority Blakeley Terminal Mobile, AL</p>
--	---

Description of Work

This Requisition solicits proposals for construction services to replace a damaged fender at Blakeley Terminal as specified in the attached pictures, drawing, and scope of work. All work shall be in accordance with the requirements stated herein, Scope of Work Specifications, Reference documents and drawings, Insurance Requirements and applicable State of Alabama and Federal Laws. The project site is located at Blakeley Terminal in Mobile, AL.

The work consists principally of providing bonds, labor, materials, equipment, insurance, and supervision necessary for the removal of damaged sections of fender system, purchase and installation of new fender system, and disposal of all removed materials associated with the work. The project includes, but is not limited to, the purchase and installation of rubber cell fender units, chain assemblies, bolts and all associated hardware. All materials, labor, tools, rigging and equipment necessary to perform the work shall be included by the Contractor in the proposal. It is the Contractor’s responsibility to field verify all dimensions and site conditions essential for the successful completion of the work. The Contractor shall not be entitled to any additional compensation for any work or expense resulting from the neglect of verifying all existing site conditions.

All Contractors submitting bids are to carefully examine the site of the proposed work and thoroughly review the contract requirements prior to submission of a bid proposal. Each Bidder shall satisfy oneself as to the character, quality, and quantities of work to be performed, and as to the requirements of the proposed contract. The submission of a proposal shall be proof that the bidding Contractor has made such examination and is satisfied as to the conditions to be encountered in performing the work and as to the requirements of the proposed Contract. All bidding Contractors must hold a current license from the State Licensing Board for General Contractors, Montgomery, AL with the classification of **(H/RR) Heavy/Railroad, (H/RR-S) Specialty Construction-Marine Construction, or (H/RR-S) Piers.**

An optional pre-bid meeting is scheduled for Thursday, September 29, 2022 at 9:00 a.m. at the north end of Blakeley Terminal. **All bidders without proper access credentials must contact the project manager at least 24 hours in advance to set up an escort into the facility.** Electing to not visit the site before bidding will not relieve the prospective bidders from the previously stated requirements regarding the submission of a proposal.

The work performed under this contract shall not commence until the Contractor has submitted a Performance Bond, Labor & Material Bond, and Certificate of Insurance in an acceptable form. Performance Bond and Labor & Material Bonds shall be in an amount equal to 100% of the contract



Alabama State Port Authority **Requisition and Proposal**

Project Name Blakeley Fender Repair

Project No. 11127 Task No. 01

2 | Page

price; Certificate of Insurance shall be as per the attached requirements and countersigned by a licensed resident agent in the State of Alabama.

The Contractor shall comply with all Federal and State laws, local ordinances and regulations, and all orders and decrees of bodies or tribunals having any jurisdiction or authority, which in any manner affect those engaged or employed on the work, or which in any way affect the conduct of the work.

The Contractor will be required to complete the work under the Contract within 150 calendar days after receipt of a "Notice to Proceed". Work will start and the Contractor will be required to furnish proof of purchase of materials within 10 calendar days after receipt of notice to proceed. The work will have to be scheduled and performed in a manner that will not interfere with the operations of the facility ongoing in the immediate and adjacent areas. ASPA intent is that work hours will be during normal day light hours.

ASPA cargo handling operations take priority over construction activities, therefore the Contractor will be required to relocate his operations as necessary to facilitate marine vessel berthing. ASPA Operations will make every effort to inform the Contractor of the vessel berthing schedule as far in advance as possible. For information purposes only, vessels berth in this location approximately 3 times per month. The work area is directly adjacent to active wharfs with marine and land activity in the general vicinity of the work area, thus the Contractor must coordinate closely with ASPA Engineering and Operations personnel to schedule work activities to ensure that they do not interfere with normal operations. Notice is given that cargo operations takes precedence over construction activities. The Contractor shall plan work activities in such a way as to keep the maximum amount of wharf area orderly and accessible during all phases of the project. The Contractor must provide a high visibility temporary barrier to delineate the limits of construction activities on the pier at all times. The Contractor must capture and dispose of all waste materials generated by the construction activities. No debris will be allowed to fall into the water below. The Contractor is responsible for the disposal of all waste materials associated with the work.

The Contractor shall place a competent superintendent on the Project who shall have experience in the work being performed under the Contract. The assigned superintendent shall have the responsibility for the day-to-day operations of the work and shall remain on the Project site while the work under the Contract is being performed. It is the responsibility of the Contractor to become familiar with all conditions affecting the nature and manner of the work.

The Contractor will agree to comply with the safety rules, standards and regulations of the Federal Occupational Safety and Health Administration (OSHA) applicable to each of its operations, and to those established and recommended safety standards inherent in the industry; and to comply with U.S. Coast Guard regulations applicable to waterfront facilities and the policies of the Alabama State Port Authority while occupying any property of the Alabama State Port Authority.

The Alabama State Docks is a full time operating facility; operating 24 hours a day, 365 days a year, including nights, weekends and holidays. The successful Contractor will be required to familiarize itself with and conform to all Port safety requirements and procedures.



Alabama State Port Authority ***Requisition and Proposal***

Project Name Blakeley Fender Repair

Project No. 11127 Task No. 01

3 | Page

Time is an essential element in the contract. As the prosecution of the work will inconvenience the tenant and interfere with business, it is important that the work be pressed vigorously to completion. Also, the cost to the Alabama State Port Authority of the administration of the contract, supervision, inspection and engineering will be increased as the time occupied in the work is lengthened. Therefore, exclusive of Sundays and national holidays, for each day that the work remains incomplete after the time specified, an amount of \$500.00 shall be paid by the contractor to the Alabama State Port Authority as liquidated damages for the loss sustained by the State because of failure of the contractor to complete the work within the specified time.

IMPORTANT NOTICE TO BIDDERS REGARDING ACCESS TO ASPA RESTRICTED FACILITIES:

The Alabama State Port Authority's Access Policy is provided on the ASPA website and in the links below:

<https://www.alports.com/port-access/>

ALL persons working on this project are REQUIRED to have valid access credentials to include: 1) A TWIC Card 2) ASPA Badge 3) ASPA Vehicle Decal.

IMPORTANT NOTICE TO BIDDERS REGARDING EMPLOYMENT PRACTICES:

Effective October 1, 2011, the Beason-Hammon Alabama Taxpayer and Citizen Protection Act ("the Act") requires that any business entity contracting with or providing any grant or incentives to the state, including the Alabama State Port Authority, certify compliance with the Act. All Bidders must certify such compliance by executing the enclosed Certificate of Compliance and returning it to the Alabama State Port Authority with your bid package along with proof of the contractor's enrollment in the e-verify program. The following E-Verify website link is provided for convenience:

http://www.dhs.gov/files/programs/gc_1185221678150.shtm.



Alabama State Port Authority
Requisition and Proposal

Project Name Blakeley Fender Repair

Project No. 11127 Task No. 01

Contractor's Proposal				
The Contractor hereby agrees to perform the specified work for the prices outlined in the following schedule. All items listed shall be performed in accordance with this requisition and proposal and all referenced documents.				
Description	Est Qty	UOM	Unit Price	Value
1. Project Mobilization	1	LS	LS	\$ _____
2. Bonds, Insurance & Port Access Credentials.	1	LS	LS	\$ _____
3. Removal of cylinder rubber element, both the torn portion that remains fastened to the pier at Cap Log 25 and portion that was removed	1	LS	LS	\$ _____
4. Furnish and install one cylinder rubber element, at Cap Log 25, including chains and mounting hardware.	1	LS	LS	\$ _____
5. Reuse and reinstall protector panel. Replace low friction pads.	1	LS	LS	\$ _____
6. Demobilization	1	LS	LS	\$ _____
<u>TOTAL BASE BID</u>				\$ _____



Alabama State Port Authority *Requisition and Proposal*

Project Name Blakeley Fender Repair

Project No. 11127 Task No. 01

5 | Page

NOTES:

1. Sealed bid proposals will be received via courier to the Alabama State Port Authority, 1400 Alabama State Docks Blvd, Suite 216, Administration Building, Mobile, AL 36602 by 1:30 P.M. on Thursday, October 13, 2022. Sealed bid proposals can also be hand delivered to the Killian Room starting at 15 minutes prior to the official bid opening at 2:00 PM on Thursday, October 13, 2022 at the Alabama State Port Authority in the International Trade Center building, 250 North Water Street, 1st floor—Killian Room, Mobile, AL. No bids will be accepted after 2:00 P.M. No faxed or electronic bids will be accepted. Conditional bids will not be accepted.
2. Bid proposals must be submitted in sealed envelopes with the words **“Bid Document Enclosed”** clearly marked on the outside of the envelope. Sealed bids shall have **the bidder’s name, contractor’s license number, project name, and time and date of bid opening shown on the outside of the envelope.**
3. A Bid Bond or Certified Check made payable to the Alabama State Port Authority and equal to five percent (5%) of the amount bid, not to exceed \$10,000, must accompany the Bid Proposal.
4. Authority reserves the right to refuse to issue a proposal form or a contract to a prospective bidder for any of the following reasons:
 - a) Failure to pay, or satisfactorily settle, all bills due for labor and materials on former contract in force with the Authority.
 - b) Contractor default under previous Contract with the Authority.
 - c) Proposal withdrawal or Bid Bond forfeiture on previous project with the Authority.
 - d) Unsatisfactory work on previous contract with the Authority.
 - e) Lack of competency, past experience, adequate machinery or lack of personnel.
5. Authority may make such investigations as deemed necessary to determine the ability of the bidder to perform the work, and the bidder shall furnish all such information and data for this purpose as the Authority may request. The Authority reserves the right to reject any bid if the evidence submitted by, or investigation of, such bidder fails to satisfy the Authority that such bidder is properly qualified to carry out the obligations of the Contract.
6. The Owner may terminate the contract, or any portion thereof, for just cause by written notice to the Contractor. If the contract, or any portion thereof, is terminated before completion of all items of work in the contract, payment will be made for the actual number of units or items of work completed or started. No claims for loss of anticipated profits will be considered.
7. If the Contractor to whom this contract is awarded does not provide adequate service or workmanship, ASPA reserves the right to cancel the contract and re-bid this work excluding that Contractor from consideration.
8. Any questions regarding the procurement should be directed to Matthew Thomas, E.I., Project Manager, at phone number (251) 441-7242 or email matthew.thomas@alports.com.
9. The right is reserved, as the interest of the Alabama State Port Authority may require, to reject any and all bids and to waive informalities in bids received.
10. The Contractor must provide a high visibility temporary barrier to delineate the limits of construction activities on the piers at all times.
11. The cost of all items ancillary to the project shall be absorbed into the cost of the bid items. No separate payment shall be made for these items.



Alabama State Port Authority
Requisition and Proposal

Project Name Blakeley Fender Repair

Project No. 11127 Task No. 01

SIGNATURES

Receipt of following addendums is acknowledged:

- Addendum No. _____
- Addendum No. _____
- Addendum No. _____
- Addendum No. _____

REFERENCED DOCUMENTS

- Alabama State Port Authority – Insurance Requirements for Contract Work
- Certificate of Compliance with the Beason-Hammon Alabama Taxpayer & Citizen Protection Act
- Reference Photos
- Reference Drawing - Blakeley Dock Plan View and Fender Detail

Contractor's Signature:		
Contractor Company _____		
_____	_____	_____
Name	Title	Date

Signature of Party Originating Requisition:

Matthew Thomas, E.I. Project Manager	Date
---	------



Alabama State Port Authority

Requisition and Proposal

Project Name Blakeley Fender Repair

Project No. 11127 Task No. 01

7 | Page

SCOPE OF WORK SPECIFICATIONS

SECTION 501 GENERAL PROVISIONS

The following detail Specifications, taken in conjunction with the pictures and drawing, describe the work to be performed by the Contractor. They amplify and explain most items in connection with the work, but do not alter the scope of same as described elsewhere in this requisition.

All materials used in the work, which are not described specifically, shall be of the best quality that it is customary to employ in construction of the character involved. The following details are not necessarily complete in the description of all items entering into the work but are intended to furnish a basis for acceptance of the more important items. Other details shall be consistent with them.

Any detail which may be incomplete or lacking in the pictures, drawing, and specifications shall not constitute claim for extra compensation. Such detail shall be supplied by the Contractor and submitted to the Engineer in advance of its requirement on the job. The true intent of the plans and specifications is to produce a complete working system and incomplete detail will not abrogate this intent.

It is the intent to follow the pictures, drawing, and specifications closely in all details, elevations, dimensions, etc., but it is understood that alterations may be required to conform to local conditions and that such alterations must be of the same character of construction as that specified. Workmanship shall be of the best quality in each class of work.

SECTION 502 SUMMARY OF THE WORK

502-01 SUMMARY

This section includes work covered by the Contract Documents and identifies the work sequence.

502-02 WORK COVERED BY THE CONTRACT DOCUMENTS

The work consists of the following:

1. Mobilization of supplies, equipment, and personnel to site for project execution.
2. Removal of cylinder rubber element, both the torn portion that remains fastened to the pier at Cap Log 25 and portion that was removed and stored at the South end of the Pier
3. Furnish and install one cylinder rubber element, at Cap Log 25, including chains and mounting hardware.
4. Reuse and reinstall protector panel. Replace low friction pads.
5. Demobilization from site.

502-03 WORK SEQUENCE

Insofar as practical, the order of work will be as scheduled by the Contractor and approved by the Project Engineer. The Contractor is required to submit a tentative schedule detailing the sequence of events and time frame for Contractor's activities. Contractor's attention is directed to the fact that the facility's cargo handling operation is a priority item, therefore, close coordination with ASPA Operations



Alabama State Port Authority **Requisition and Proposal**

Project Name Blakeley Fender Repair

Project No. 11127 Task No. 01

8 | Page

and the project engineer is required. All fabrication is to be completed before the Contractor occupies the pier. The removal and installation of the new fender system shall be fully completed in one section before moving to another section.

502-04 ACCESS FOR EQUIPMENT AND TRAFFIC

It is ASPA's intent to have full use of pier surface area for storage, traffic, and cargo handling operations during the life of this contract, thus it will be necessary for the Contractor to coordinate his operations and make suitable provisions to accommodate such. Interruption or restriction of cargo handling operations will not be permissible.

502-05 VERIFICATION OF EXISTING CONDITIONS

It is necessary for the Contractor to verify all existing conditions affecting the work. The Contractor is to familiarize self with all aspects of the project, particularly existing conditions, elevations, and surrounding activities.

502-06 ORDER OF WORK

It is essential that ASPA utilize its pier and warehouse space in the most efficient manner practical. Therefore, the Contractor work described within these Specifications must be completed within the time allotment given. The Contractor shall so schedule his operations to complete the work accordingly.

SECTION 503 REMOVAL WORK

503-01 SCOPE

This section covers the removal of all fender components within the limits shown and damaged fender items which are designated in the pictures. This shall include the following:

- All components of the existing fender system shown on the contract drawing and pictures.
- All hardware and accessories. Items designated to be reused must be maintained by the contractor.
- Any minor items which may not be shown or specified herein, but which are found to interfere with replacement work.
- Note that protector panel shall remain on site for re-use.

503-02 PROTECTION OF EXISTING STRUCTURES

The removal and disposal work required under this Contract shall be performed in such a manner so as not to damage any existing structures and any damage thereto by the Contractor's operation shall be repaired by the Contractor at no cost to ASPA. The load capacity of the existing pile-supported wharf is estimated at 1000 psf for uniformly distributed loads over surface. The Contractor shall take necessary precautions to avoid overloading this structure.

503-03 REMOVAL OF RUBBER FENDERS AND HARDWARE

The existing fender system shall be removed within the areas designated on the referenced pictures. Rubber fenders and all associated hardware shall be removed and disposed. All removed material shall



Alabama State Port Authority

Requisition and Proposal

Project Name Blakeley Fender Repair

Project No. 11127 Task No. 01

9 | Page

become property of the Contractor and shall be disposed outside ASPA property in accordance with all governing laws and regulations.

SECTION 504 FENDER SYSTEM

504-01 SCOPE

The work covered by this section shall consist of furnishing all plant, labor, materials, tools, equipment and incidentals necessary for the installation of new fender system as indicated on the referenced pictures and drawing and/or specified herein.

504-02 GENERAL

The Contractor shall visit the premises to thoroughly familiarize self with all details of the work and working conditions, to completely survey and verify all dimensions in the field, and to advise the Project Manager of any discrepancies.

Complete shop drawings showing exact field dimensions shall be submitted to the Project Manager for review before fabrication. The Contractor shall be responsible for all errors of detailing, fabrication, and for correct fitting of the fender system.

504-03 MATERIALS

All materials shall be new and conform to the following:

- A. Bolts and Nuts:
High strength bolts and washers shall be used to connect rubber fenders to dock. They shall conform to ASTM A325 and shall be hot-dip galvanized as specified for unfinished bolts and nuts, Class C. Bolts must match existing location or contractor shall provide for adjustment of bolts within bid.
- B. Rubber Cell Fender Units shall match performance and dimensions of the following: replacement units shall be Bridgestone Model SUC 1000H (RS) rubber cell fenders or approved equal. The new fender elements must meet the Fender System Performance characteristics listed on the Reference Drawings.
- C. Chain Assemblies. Chains, shackles, and dog bone shackle shall be provided new and must be galvanized. Chains, shackles, and dog bone shackles must match the existing.

504-04 RUBBER FENDER UNIT INSTALLATION

The new rubber fender units shall be attached to the dock using the existing anchor bolt sleeves. New bolts and washers will be installed, and adhesive threadlocker shall be applied to the bolt threads. The bolts shall be tightened to firmly seat all components. When tightening bolts to seat the fender elements, do not allow the washer under the bolt head to be embedded more than 1/32". Any missing components shall be replaced in like kind.



Alabama State Port Authority ***Requisition and Proposal***

Project Name Blakeley Fender Repair

Project No. 11127 Task No. 01

10 | Page

504-05 CHAIN ASSEMBLY INSTALLATION

Chain assemblies shall be installed as shown on the contract drawings, using the existing chain U-anchors. The chains, shackles, and dog bone shackles for the missing fender must be provided new. The chain must be the correct length to provide tension to support the weight of the new fender system. Dog bone shackle shall be used to tension the weight chains to support the fender weight. The rubber flex element, seen in the photos, will be replaced by chain links.

SECTION 506 REFERENCED DRAWINGS AND PICTURES

506-01 LIST OF DRAWINGS AND PICTURES

1. Reference Photos
2. Reference Drawing - Blakeley Dock Plan View and Fender Detail

ALABAMA STATE PORT AUTHORITY **INSURANCE REQUIREMENTS FOR CONTRACT WORK**

INDEMNIFICATION

The Contractor shall assume all liability for and shall indemnify and save harmless the State of Alabama and the Alabama State Port Authority, doing business as Alabama State Docks (ASD), and its officers and employees from all damages and liability for injury to any person or persons, and injury to or destruction of property, including the loss of use thereof, by reason of an accident or occurrence arising from operations under the contract, whether such operations are performed by himself or by any subcontractor or by anyone directly or indirectly employed by either of them occurring on or about the premises, or the ways and means adjacent during the term of the contract, or any extension thereof, and shall also assume the liability for injury and/or damages to adjacent or neighboring property by reason of work done under the contract.

INSURANCE REQUIREMENTS

The Contractor shall not commence work under the contract until he has obtained all insurance required under the following paragraphs and until such insurance has been approved by ASD, nor shall the Contractor allow any subcontractor to commence work until all similar applicable insurance has been obtained by the subcontractor or the Contractor has provided coverage for the subcontractor. The Contractor shall provide, at his expense, insurance in accordance with the following:

General Requirements (applicable to all policies)

All policies of insurance must be written with companies acceptable to ASD. The Contractor shall furnish to ASD certificates of insurance, signed by the licensed agent evidencing required coverages. ASD reserves the right to require certified copies of any and all policies. Each policy of insurance shall provide, either in body of the policy or by endorsement, that such policy cannot be substantially altered or cancelled without thirty (30) days' written notice to ASD and to the insured. Except for Workers Compensation, said policies will identify Alabama State Port Authority, its officers, officials, agents, servants and employees as Primary and Non-contributory Additional Insureds in connection with work performed for, on behalf of, or on the property of ASD.

General Liability

The Contractor shall take out and maintain during the life of the contract Commercial General Liability insurance, including Blanket Contractual and Completed Operations coverages, in an amount not less than \$2,000,000 for any one occurrence for bodily injury, including death, and property damage liability.

Automobile Liability

The Contractor shall take out and maintain during the life of the contract Business Automobile Liability insurance covering any auto in an amount not less than \$1,000,000 for any one occurrence for bodily injury, including death, and property damage liability.

Workers Compensation

The Contractor shall take out and maintain during the life of the contract Workers Compensation and Employers Liability insurance providing coverage under the Alabama Workers Compensation Act in an amount not less than that required by Alabama law.

Where applicable, Contractor shall take out and maintain during the life of the contract insurance providing coverage as required by Federal statute, including but not limited to U.S. Longshoremen and Harborworkers' Compensation Act (USL&H), Jones Act, and Railroad Federal Employers Liability Act (FELA).

Ocean Marine

In the event work involves the use of watercraft in the completion of the contract, the Contractor shall provide Protection and Indemnity coverage, including crew, in an amount not less than \$1,000,000 for each loss.

State of _____

County of _____

CERTIFICATE OF COMPLIANCE WITH THE BEASON-HAMMON ALABAMA TAXPAYER AND CITIZEN PROTECTION ACT (ACT 2011-535, as amended by Act 2012-491)

DATE: _____

RE Contract/Grant/Incentive (describe by number or subject):

_____ by and between
_____ (Contractor/Grantee) and
_____ (State Agency, Department or Public Entity)

The undersigned hereby certifies to the State of Alabama as follows:

1. The undersigned holds the position of _____ with the Contractor/Grantee named above, and is authorized to provide representations set out in this Certificate as the official and binding act of that entity, and has knowledge of the provisions of THE BEASON-HAMMON ALABAMA TAXPAYER AND CITIZEN PROTECTION ACT (ACT 2011-535 of the Alabama Legislature, as amended by Act 2012-491) which is described herein as "the Act".
2. Using the following definitions from Section 3 of the Act, select and initial either (a) or (b), below, to describe the Contractor/Grantee's business structure.

BUSINESS ENTITY. Any person or group of persons employing one or more persons performing or engaging in any activity, enterprise, profession, or occupation for gain, benefit, advantage, or livelihood, whether for profit or not for profit. "Business entity" shall include, but not be limited to the following:

a. Self-employed individuals, business entities filing articles of incorporation, partnerships, limited partnerships, limited liability companies, foreign corporations, foreign limited partnerships, foreign limited liability companies authorized to transact business in this state, business trusts, and any business entity that registers with the Secretary of State.

b. Any business entity that possesses a business license, permit, certificate, approval, registration, charter, or similar form of authorization issued by the state, any business entity that is exempt by law from obtaining such a business license and any business entity that is operating unlawfully without a business license.

EMPLOYER. Any person, firm, corporation, partnership, joint stock association, agent, manager, representative, foreman, or other person having control or custody of any employment, place of employment, or of any employee, including any person or entity employing any person for hire within the State of Alabama, including a public employer. This term shall not include the occupant of a household contracting with another person to perform casual domestic labor within the household.

- ____ (a) The Contractor/Grantee is a business entity or employer as those terms are defined in Section 3 of the Act.
 ____ (b) The Contractor/Grantee is not a business entity or employer as those terms are defined in Section 3 of the Act.

3. As of the date of this Certificate, Contractor/Grantee does not knowingly employ an unauthorized alien within the State of Alabama and hereafter it will not knowingly employ, hire for employment, or continue to employ an unauthorized alien within the State of Alabama;
4. Contractor/Grantee is enrolled in E-Verify unless it is not eligible to enroll because of the rules of that program or other factors beyond its control.

Certified this _____ day of _____ 20 _____

Name of Contractor/Grantee/Recipient

By: _____

Its _____

The above Certification was signed in my presence by the person whose name appears above, on

this _____ day of _____ 20 _____.

WITNESS: _____

Printed Name of Witness



Damaged fender hanging from pier

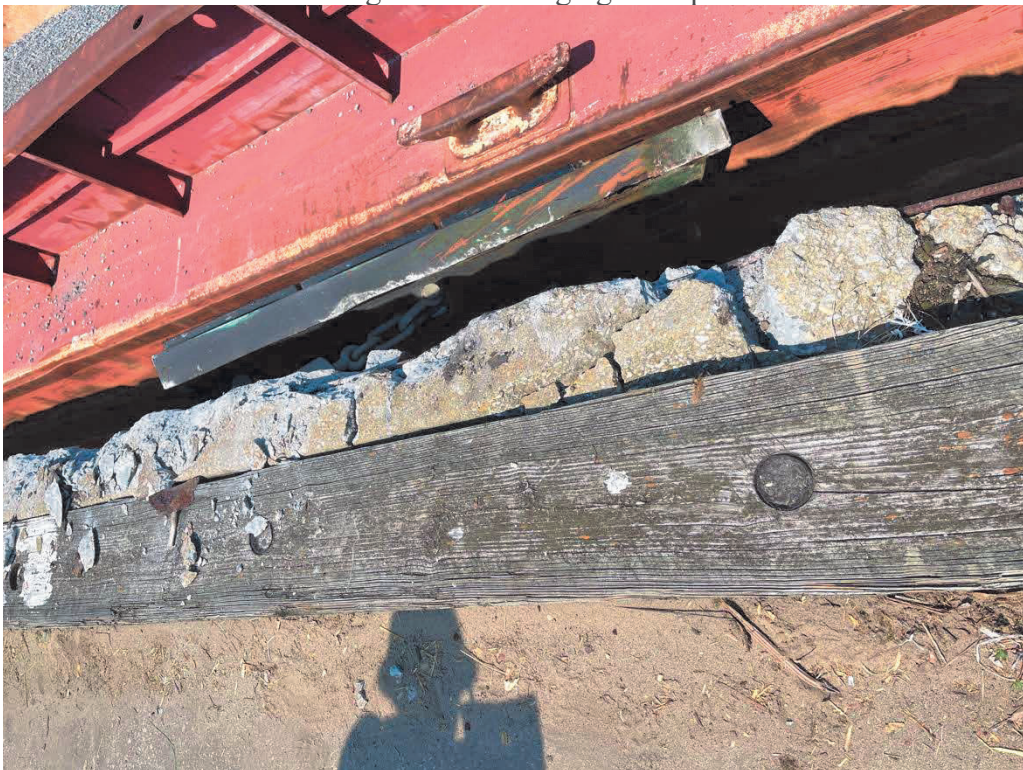

Spalled concrete in way of Cap Log 25



Fender panel recovered



Rubber Element torn

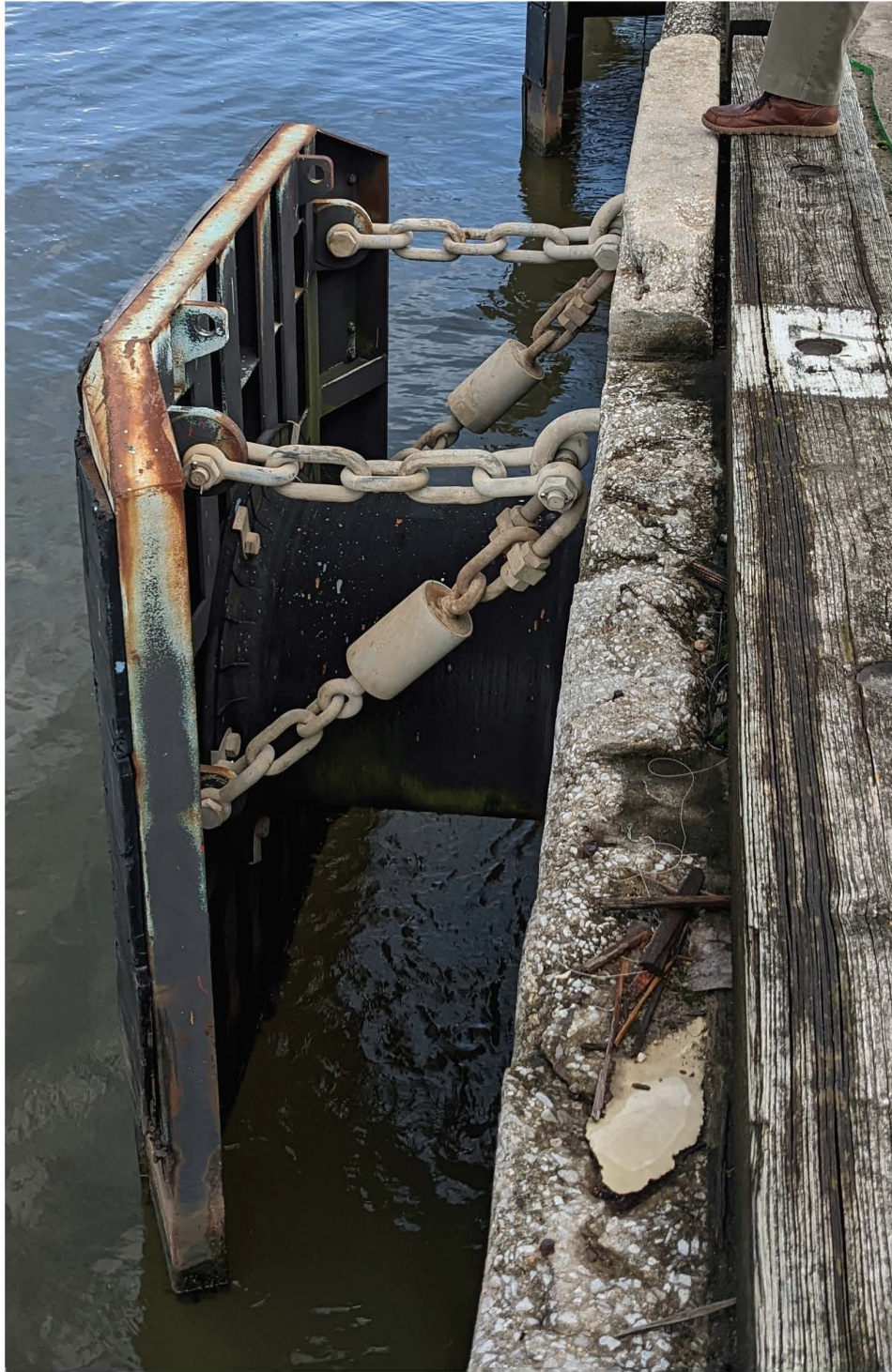

Existing Fender for Reference

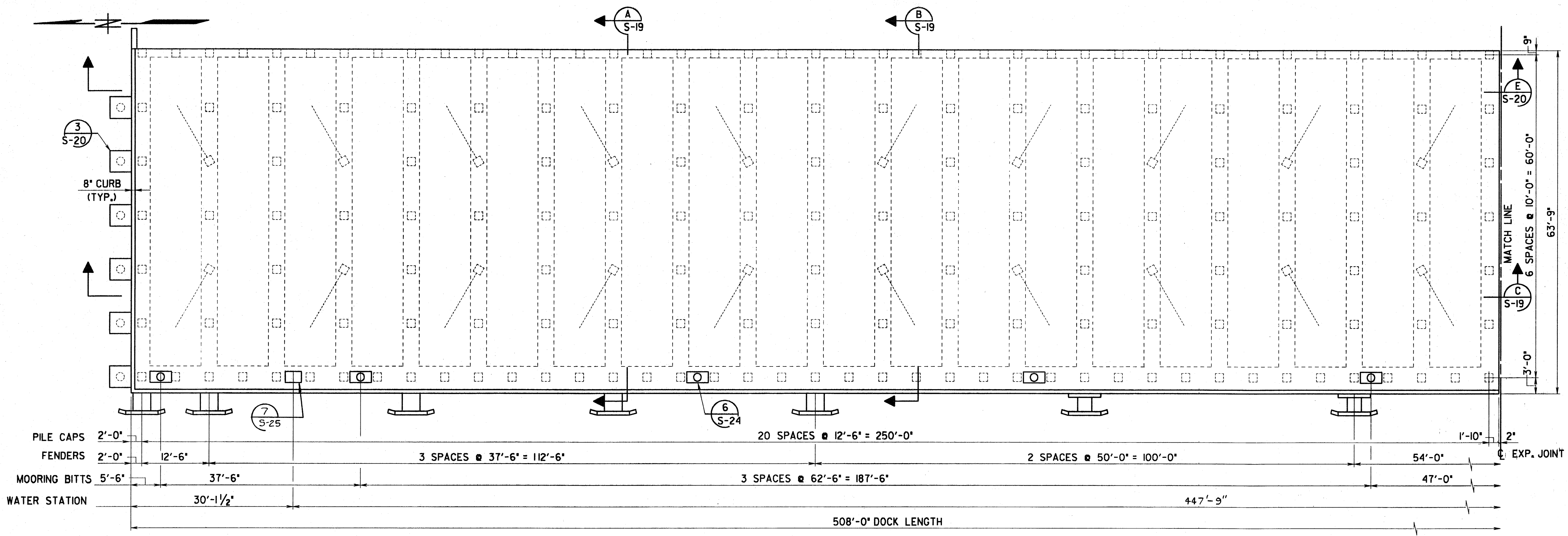

- DECK NOTES:**
1. ALL CAST IN PLACE CONCRETE FOR PILE CAPS AND BEAMS TO BE CLASS 4x1/2.
 2. ALL CAST IN PLACE CONCRETE FOR DECK TOPPING TO BE CLASS 4x3/4.
 3. ALL ELEVATIONS ARE IN FEET AND ARE BASED ON MEAN LOW WATER (MLW) DATUM.
 4. FOR DECK PANEL DETAILS, SEE SHEET NO. S-21.
 5. FOR DECK FENDER DETAILS, SEE SHEET NO. S-22.
 6. FOR MOORING BITT DETAILS, SEE SHEET NO. S-24.
 7. FOR WATER STATION DETAILS, SEE SHEET NO. S-25.
 8. FOR DOCK UTILITY PIPING PLAN AND DETAILS, SEE SHEET NOS. S-26 & S-27.
 9. FINISHES SHALL BE F-1 FOR CONCRETE SURFACES NOT EXPOSED TO VIEW, F-2 FOR CONCRETE EXPOSED TO VIEW AND S-2 FOR THE SLAB TOPPING.
 10. DECK DESIGNED FOR 1000 PSF AND 125 K CONCENTRATED LOAD ON A 2 FOOT SQUARE AREA SPACED 10'0" TRANSVERSELY AND 12'-6" LONGITUDINALLY.

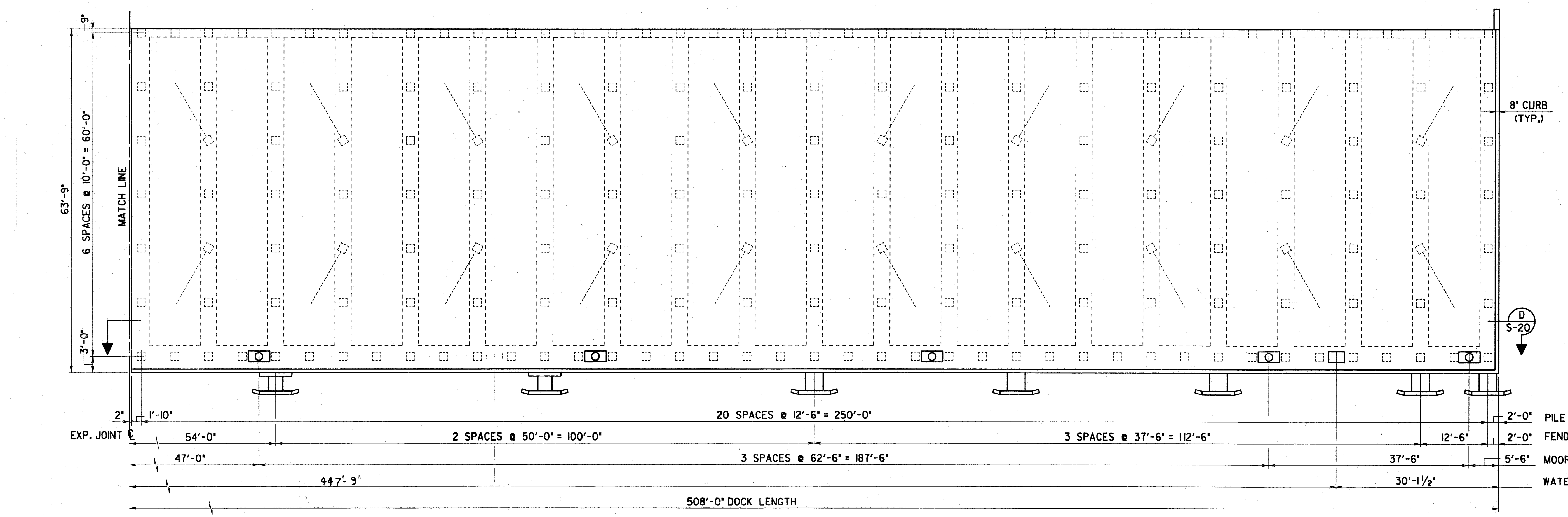

Brown & Root U.S.A., Inc.			
MOBILE ENGINEERING OFFICE			
JOB NO. LE-0026			
ISSUED FOR:	REV:	DATE:	TRANS. NO.:
CLIENT:	APPROV.:	DATE:	NO.:
CONST.:	DATE:	NO.:	NO.:

ALABAMA STATE DOCKS
MOBILE, ALABAMA

CONSTRUCTION OF DOCK AT BLAKELY FACILITY
DOCK DECK CONSTRUCTION
DOCK DECK PLAN S-18

DWG. BY:	DATE:	REVISIONS				SCALE:
MJR	8-30-89	BY:	DATE:	BY:	DATE:	1" = 10'-0"
CHEK. BY:	DATE:	BY:	DATE:	BY:	DATE:	DRAWING NO.
PKJ	9-11-89					B-11-155-19

11-SEP-1989 13:25
CADD NO. LE026C006

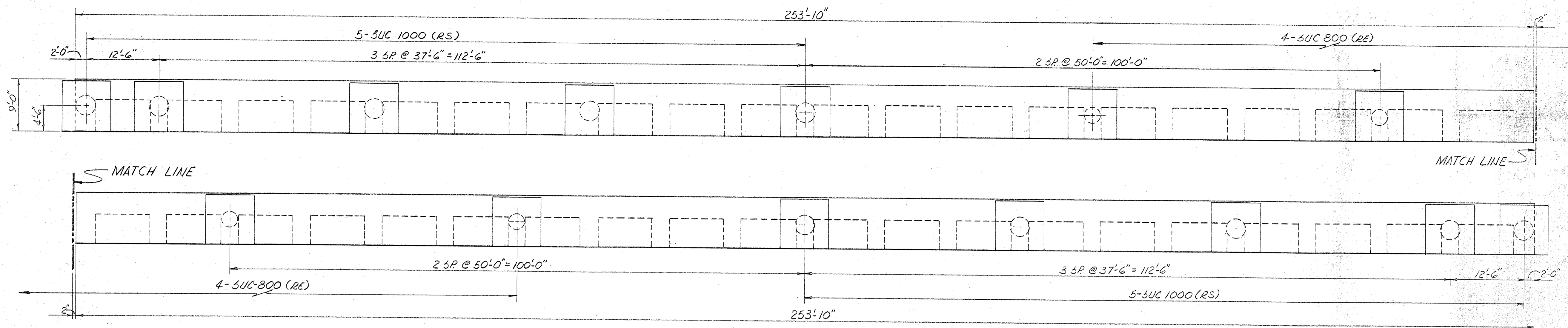

ELEVATION
SCALE: 1" = 10'-0"

NOTES:
 1) FOR DECK NOTES, SEE SHT. NO. S-18.
 2) THE MARINE FENDERS ARE TO CONSIST OF BRIDGESTONE MODEL SUC 800H (RE) X1 AND MODEL SUC 1000H (RS) X1 OR APPROVED EQUAL. SEE SPECIFICATIONS FOR ENERGY AND REACTION CRITERIA.

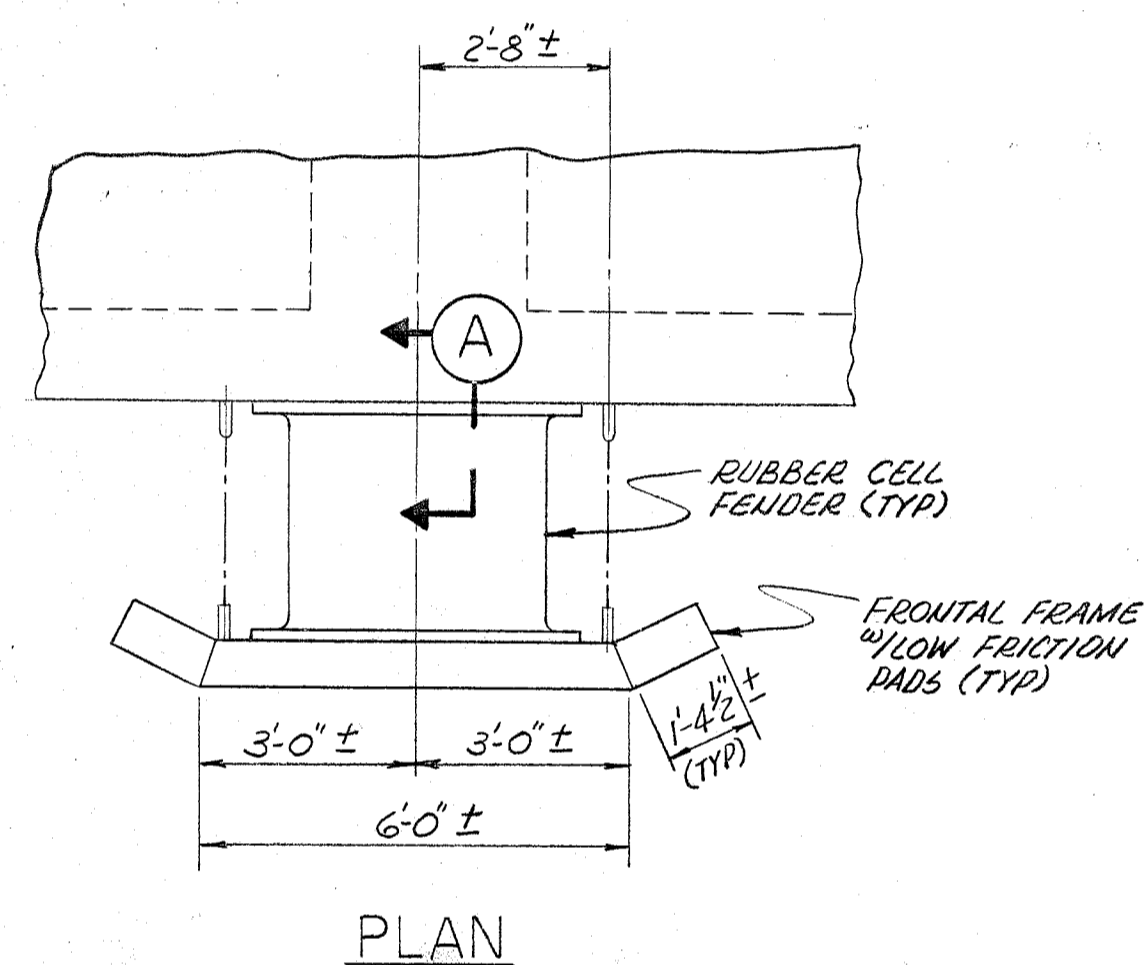

PLAN

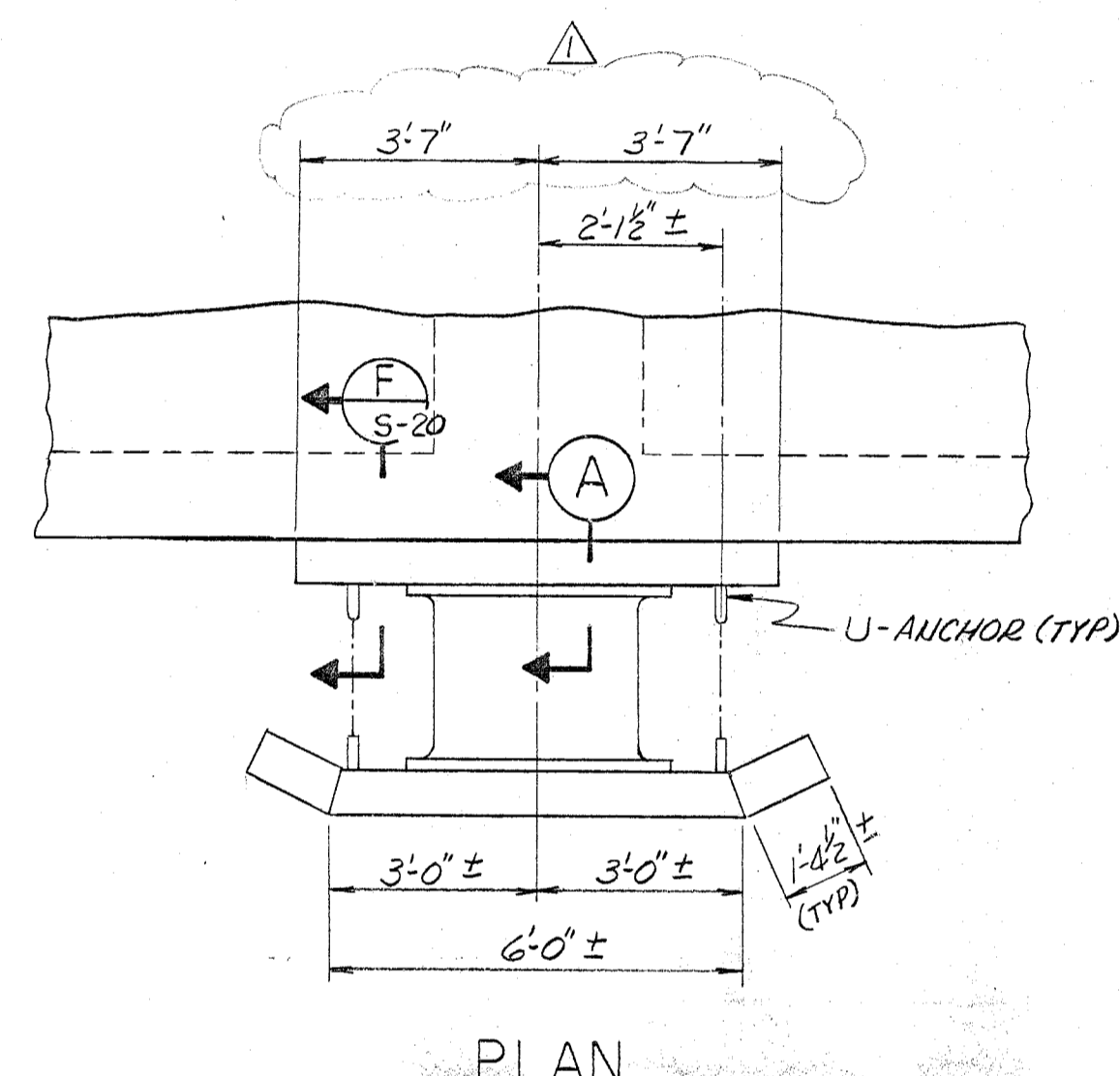

PLAN

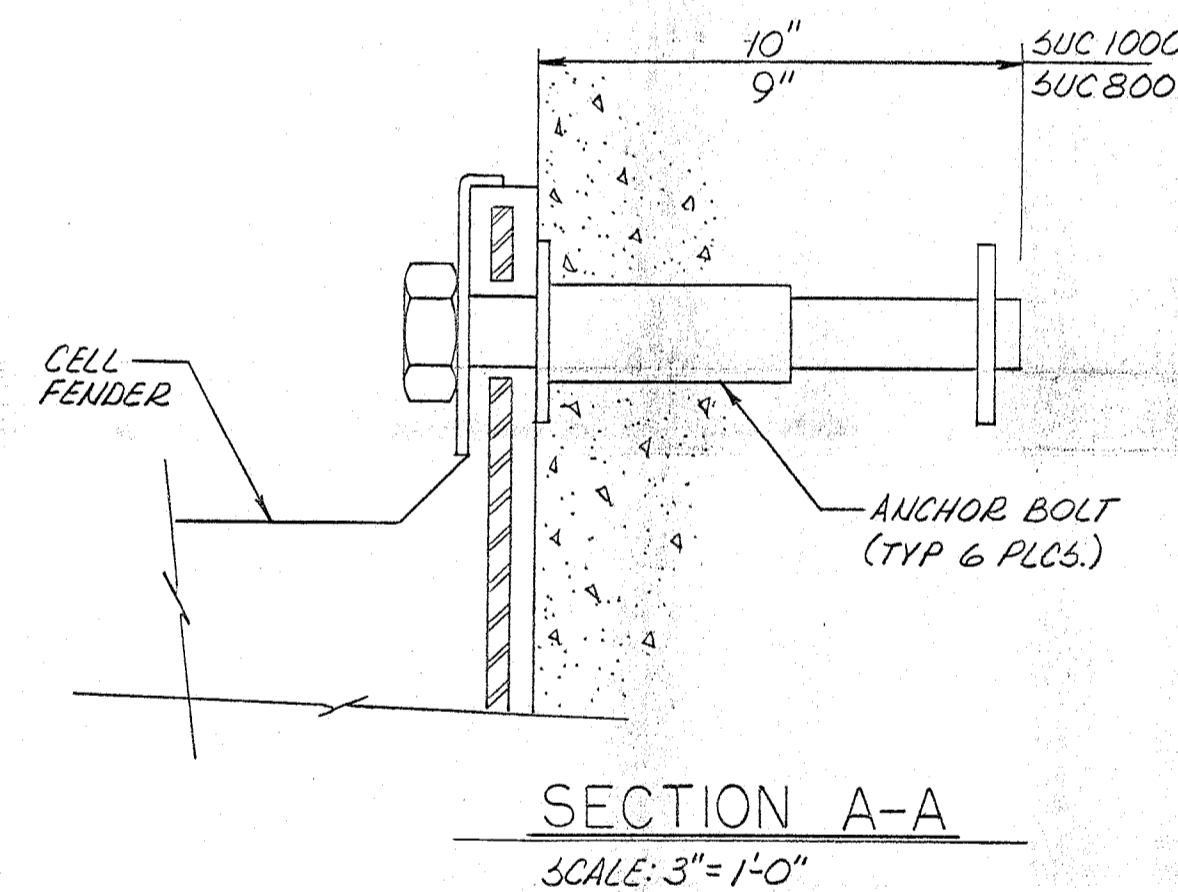

SECTION A-A
SCALE: 3" = 1'-0"

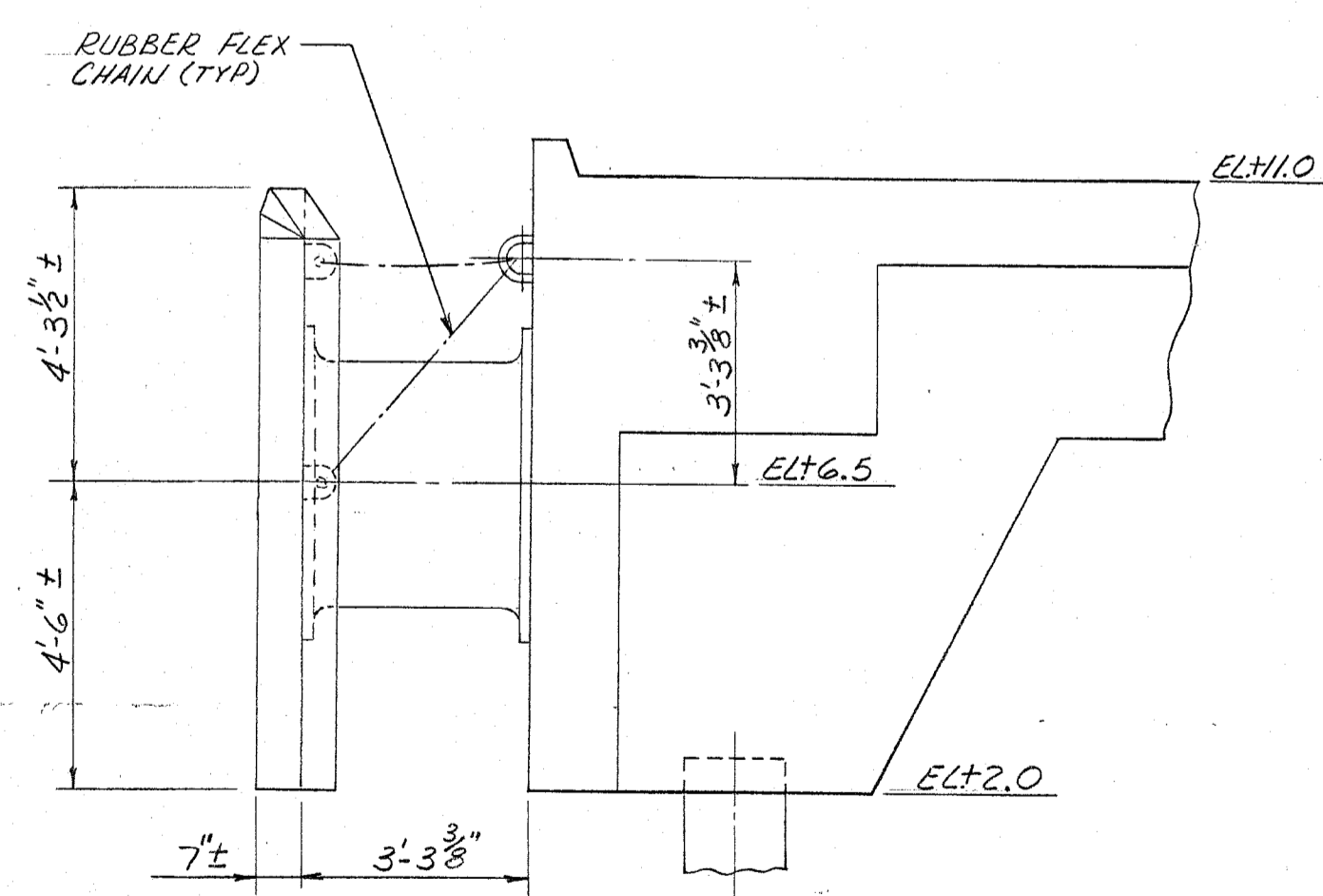

SECTION

SUC 1000H (RS)
SCALE: 3/8" = 1'-0"

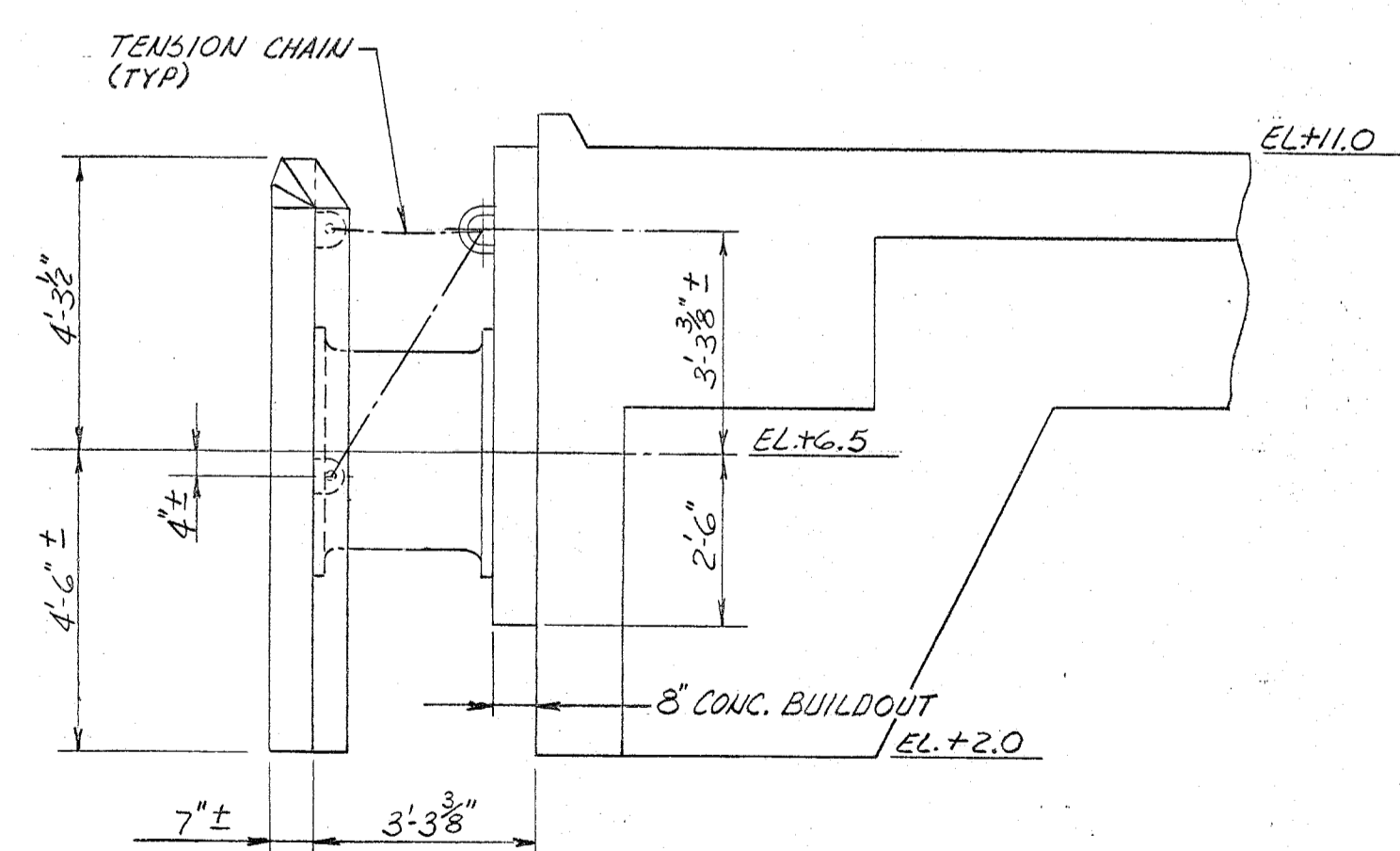

SECTION

SUC 800H (RE)
SCALE: 3/8" = 1'-0"

Brown & Root U.S.A., Inc.			
MOBILE ENGINEERING OFFICE			
ISSUED FOR REV. DATE	TRANS. NO.		
10/11/89	0016		
CONST.	1/15/90	007	
CONST.	1/15/90	008	

ALABAMA STATE DOCKS
MOBILE, ALABAMA

CONSTRUCTION OF DOCK AT BLAKELY FACILITY
DOCK DECK CONSTRUCTION
FENDER ELEVATION AND DETAILS

S-22

DWG. BY:	DATE	REVISIONS	SCALE
J. Holt	9-6-89		AS NOTED
CHKD. BY:	DATE	PKT	DRAWING NO.
PPJ	9-11-89	3-20-70	B-11-155-23